

Dynapac CA2500PD

Single drum vibratory rollers



Technical data

Masses	
Operating mass (incl. ROPS)	24,300 lbs
Operating mass (incl. Cab)	24,700 lbs
Module mass (front/rear)	14,300 lbs/10,400 lbs
Max. operating mass	26,100 lbs

Dimensions	
Drum width	84 in

Propulsion	
Speed range	0 -7,5 mph
Tire size (8 ply)	23.1 x 26 TR
Max. theoretical gradeability	57 %
Vertical oscillation	±9°
Number of pads	130
Pad area	22.6 in ²
Pad height	4 in

Compaction	
Nominal amplitude (high/low)	0.079 in/0.043 in
Vibration frequency (high/low amplitude) SEISMIC available (values for manual mode)	1,800 vpm /1,800 vpm
Centrifugal force (high/low amplitude)	58,450 lb/33,720 lb

Engine	
Manufacturer/Model	Cummins QSF3.8 (IV/4final)
Type	Water cooled turbo Diesel
Rated power, SAE J1995	89 kW (120 hp) @ 2,200 rpm
Fuel tank capacity	67 gal
DEF tank capacity	5 gal

Engine	
Manufacturer/Model	Cummins F3.8 (V)
Type	Water cooled turbo Diesel
Rated power, SAE J1995	100 kW (135 hp) @ 2,200 rpm

Engine	
Manufacturer/Model	Cummins QSB4.5 (IIIA/3)
Type	Water cooled turbo Diesel
Rated power, SAE J1995	97 kW (130 hp) @ 2,200 rpm

Hydraulic system	
Driving	Hydrostatic
Vibration	Hydrostatic
Steering	Hydrostatic
Service brake	Hydrostatic in forward and reverse lever.
Parking/Emergency brake	Failsafe multidisc brake in drum gear box and in rear axle.

Find us locally at www.dynapac.us

We reserve the right to change specifications without notice. Photos and illustrations do not always show standard versions of machines. The above information is a general description only, all informations are supplied without liability.

Dynapac CA2500PD

Single drum vibratory rollers



Technical data

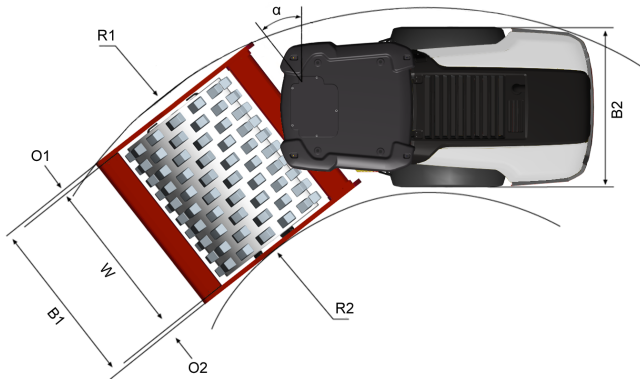
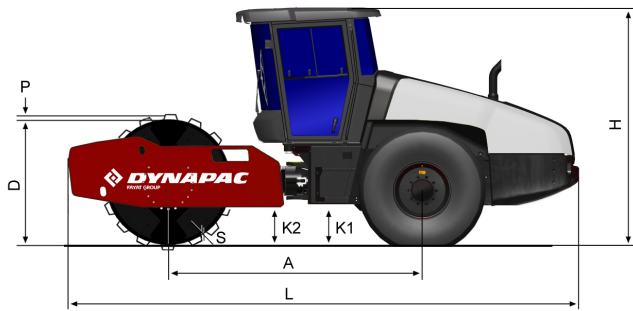

Dimensions	
A. Wheelbase	118 in
B1. Width, front	91 in
B2. Width, rear	84 in
D. Drum diameter	59 in
H. Height, with ROPS/cab	117 in
H1. Height, with ROPS/cab	117 in
H2. Height, w/o ROPS/cab	87 in
K1. Ground clearance	18 in
K2. Curb clearance	18 in
L. Length	236 in
O1. Overhang, right	4 in
O2. Overhang, left	4 in
P. Pad height	4 in
R1. Turning radius, outside	215 in
R2. Turning radius, inside	130 in
S. Drum shell thickness	0.79 in
W. Working width	84 in
α. Steering angle	±38°



Standard equipment

- 24V outlet socket, operator's platform
- AntiSpin or Traction Control drive system
- Automatic vibration control
- Back up alarm
- Brake release
- Cab or ROPS/FOPS
- Cross Mounted Engine
- Combi cooler with Hydraulically driven fan
- Display: Engine temp, Fuel level, Hydr. temp, Speedometer, Tachometer, Voltage
- ECO mode
- Emergency stop
- Filler cap inside lockable hood
- Hydraulic checkpoints
- Parking brake
- Rear axle, No-Spin or Limited Slip
- **Seismic with Compaction Meter including Active Bouncing Control**
- Shock mounted platform
- Steering wheel, adjustable
- Suspension seat, swivelling
- Storage Compartment
- Vandal cover
- Warning lights: Air cleaner, Brake, Clogged hyd. fluid filter, Engine oil pressure/temp, Hyd oil temp, Low charge, Low fuel
- 1m X 1m Visibility
- Zero spill oil & coolant change

Find us locally at www.dynapac.us

We reserve the right to change specifications without notice. Photos and illustrations do not always show standard versions of machines. The above information is a general description only, all informations are supplied without liability.



Optional equipment

Air Conditioning /Automatic Climate Control (ACC) (Optional)

- The system contains fluorinated greenhouse gases.
- Coolant designation: HFC-134a
- Coolant weight when full: 1,35 kg
- CO₂-equivalent: 1,930 ton
- GWP: 1430

Find us locally at www.dynapac.us

We reserve the right to change specifications without notice. Photos and illustrations do not always show standard versions of machines.
The above information is a general description only, all informations are supplied without liability.