

Dynapac CA2500PD HC

Single drum vibratory rollers



Technical data



Masses

Operating mass (incl. ROPS)	24,300 lbs
Operating mass (incl. Cab)	24,700 lbs
Module mass (front/rear)	14,300 lbs/10,400 lbs
Max. operating mass	26,100 lbs



Dimensions

Drum width	84 in
------------	-------



Propulsion

Speed range	0 -7.5 mph
Tire size (8 ply)	23,1 x 26 TR
Theor. gradeability, forward	55 %
Theor. gradeability, reverse	55 %
Vertical oscillation	±9°
Number of pads	130
Pad area	22.6 in ²
Pad height	4 in



Compaction

Nominal amplitude (high/low)	0.079 in/0.043 in
Vibration frequency (high/low amplitude)	1,800 vpm/1,800 vpm
Centrifugal force (high/low amplitude)	58,450 lb/33,720 lb



Engine

Manufacturer/Model	Cummins QSF3.8 (IV/4final)
Type	Water cooled turbo Diesel
Rated power, SAE J1995	89 kW (120 hp) @ 2,200 rpm
Fuel tank capacity	72 gal
DEF tank capacity	5 gal



Engine

Manufacturer/Model	Cummins QSB4.5 (IIIA/3)
Type	Water cooled turbo Diesel
Rated power, SAE J1995	97 kW (130 hp) @ 2,200 rpm



Hydraulic system

Driving	Hydrostatic
Vibration	Hydrostatic
Steering	Hydrostatic
Service brake	Hydrostatic in forward and reverse lever.
Parking/Emergency brake	Failsafe multidisc brake in drum gear box and in rear axle.

Find us locally at www.dynapac.us

We reserve the right to change specifications without notice. Photos and illustrations do not always show standard versions of machines. The above information is a general description only, all informations are supplied without liability.

Dynapac CA2500PD HC

Single drum vibratory rollers



Technical data

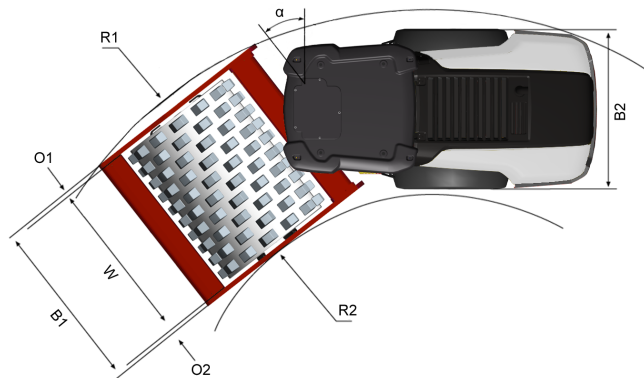
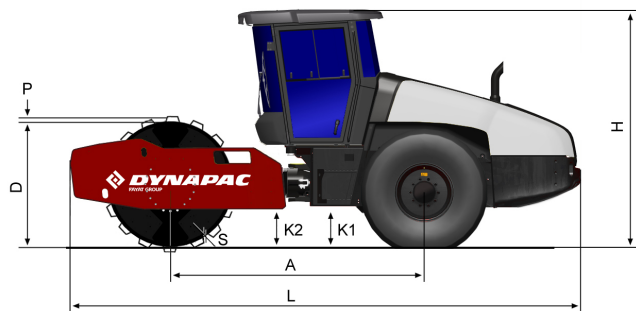

Dimensions	
A. Wheelbase	118 in
B1. Width, front	91 in
B2. Width, rear	84 in
D. Drum diameter	59 in
H. Height, with ROPS/cab	117 in
H1. Height, with ROPS/cab	117 in
H2. Height, w/o ROPS/cab	87 in
K1. Ground clearance	18 in
K2. Curb clearance	18 in
L. Length	236 in
O1. Overhang, right	4 in
O2. Overhang, left	4 in
P. Pad height	4 in
R1. Turning radius, outside	215 in
R2. Turning radius, inside	130 in
S. Drum shell thickness	0.79 in
W. Working width	84 in
α. Steering angle	±38°



Standard equipment

- 24V outlet socket, operator's platform
- Automatic vibration control
- Back up alarm
- Brake release
- Cross Mounted Engine
- Combi cooler with Hydraulically driven fan
- Display: Engine temp, Fuel level, Hydr. temp, Speedometer, Tachometer, Voltage
- Dual speed drum drive motor
- Emergency stop
- Filler cap inside lockable hood
- Hydraulic checkpoints
- Parking brake
- Shock mounted platform
- Steering wheel, adjustable
- Suspension seat, swivelling
- Storage Compartment
- Vandal cover
- Warning lights: Air cleaner, Brake, Clogged hyd. fluid filter, Engine oil pressure/temp, Hyd oil temp, Low charge, Low fuel
- 1m X 1m Visibility
- Zero spill oil & coolant change

Find us locally at www.dynapac.us

We reserve the right to change specifications without notice. Photos and illustrations do not always show standard versions of machines. The above information is a general description only, all informations are supplied without liability.