

QUICK SPECS

Weight	8,422 lbs
Horsepower	39 HP
Bucket Capacity	0.65 yd ³

Never met a challenge it couldn't handle.

The V4-7 is powered by 39 HP Tier 4 Final YANMAR engine. It is packed with power combined with exceptional performance whether you are moving mounds of rocks or dirt or moving piles of fertilizer. The V4-7 comes with several convenient functions and features to provide ease of operation and easy maintenance. Couple that with a more comfortable, operator-friendly cab and this compact loader always comes up big when you need it most.



V4-7

POWERFUL, EFFICIENT 39-HP WATER-COOLED TIER 4 FINAL YANMAR DIESEL ENGINE

FULLY AUTOMATIC ACCELERATOR MODE

FIXED TRAVEL SPEED MODE FOR ADDED SAFETY IN RESTRICTED AREAS

BATTERY DISCONNECT SWITCH

STANDARD PARKING BRAKE PEDAL WITH RELEASE LEVER

AUXILIARY HYDRAULICS W/ PROPORTIONAL CONTROL STANDARD

STANDARD RECLINING SUSPENSION SEAT WITH SEATBELT

COMPONENT ACCESS FOR DAILY MAINTENANCE

OPTIONAL ENCLOSED CAB WITH HEAT & A/C

INNOVATIVE FEATURES



Rear Axle Oscillation

With Rear Axle Oscillation, you can work quickly and more efficiently on uneven ground because the traction force is transmitted securely to the ground. This ensures the bucket or load remains level in operation. And because the effects of slopes and bumps are minimized, operator fatigue is significantly reduced, too.



Everything Right at Your Fingertips

The V4-7 comes standard with ECO Mode, 2-speed operation, fully automatic mode, fixed speed mode and a joystick bucket control incorporated right into the operator's station. Plus, you get an innovative LCD monitor, showing key operating information and maintenance notification intervals.



Newly Designed Operator Station

Our newly upgraded operator's station has a wider entrance and a suspension seat, a real plus when you've got to spend a long day on the job



V4-7

Dimensions - V4-7

A 14 ft. 6 in. (4,425 mm)	G 1 ft. 3 in. (370 mm)
B 6 ft. 2 in. (1,880 mm)	H 12 ft. 3 in. (3,730 mm)
C 5 ft. 7 in. (1,690 mm)	I 2 ft. 7 in. (790 mm)
D 8 ft. 5 in. (2,555 mm)	J 12 ft. 6 in. (3,805 mm)
D' 8 ft. 4 in. (2,545 mm)	K 9 ft. 10 in. (3,005 mm)
E 4 ft. 1 in. (1,240 mm)	
F 7 ft. 11 in. (2,420 mm)	

D: Canopy Specifications

D': Cabin Specifications

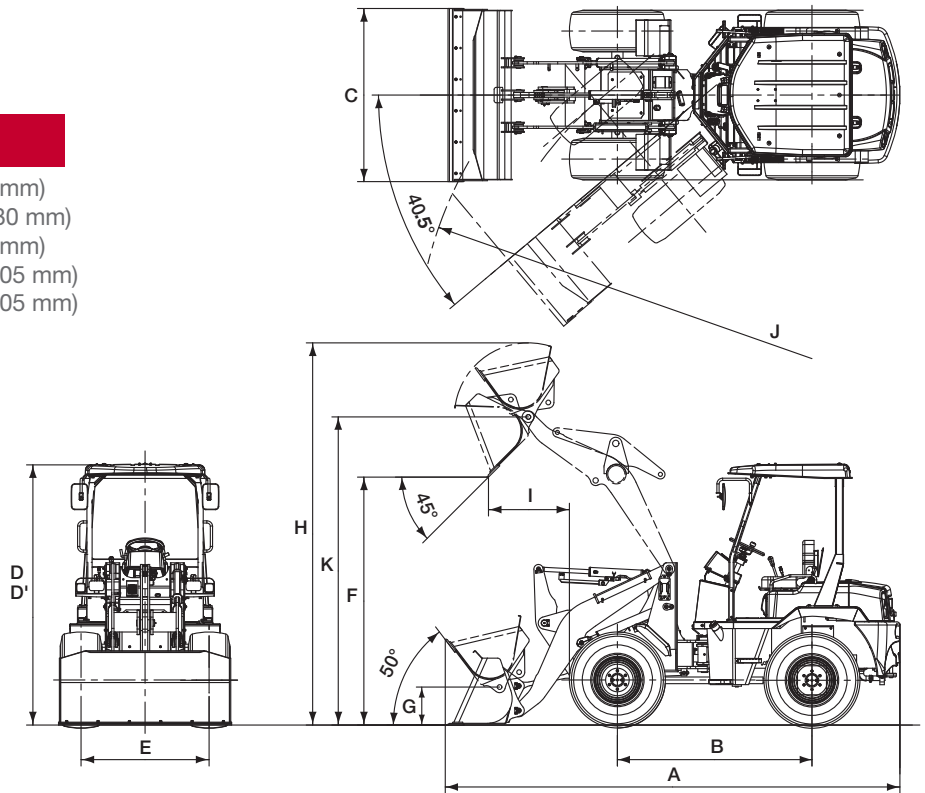

Specifications

Model		V4-7	
Engine	Type	-	
	Model	-	
	Output	HP (kw)/rpm	
	Displacement	in ³ (cm ³)	
Performance	Standard Bucket Capacity	yd ³ (m ³)	
	Operating Load	lbs (kN)	
	Lifting Capacity at Low End	lbs (kN)	
	Tipping Load	Straight	lbs (kN)
		Full Turn	lbs (kN)
	Breakout Force	lbs (kN)	
	Dumping Clearance	ft-in (mm)	
	Traveling Speed	mph (km/h)	
	Oscillation Angle	degrees	
	Minimum Turning Radius	ft-in (mm)	
	Min. Ground Clearance	ft-in (mm)	
PTO	Front Hyd. PTO	PSI (kPa)	
		GPM (L/min)	
Steering	Type	-	
	Articulate Angle	degrees	
Transmission	Type	-	
Drives	Type	-	
Wheels	Type	-	
Brakes	Type	-	
Operating Weight	Canopy	lbs (kg)	
	Cabin	lbs (kg)	
Transport Dimensions	L x W x H	ft-in (mm)	

Please note that the standard equipment may vary from this list. Consult your YANMAR dealer for confirmation.