

Technical sheet :

# ***ULM 415 H***

---



| Capacities  |     | Imperial  |
|---|-----|---|
| Max. capacity   | Q   | 3307 lb   |
| Max. lifting height   | h3  | 14 ft 1 in                                      |
| Max. outreach   |     | 8 ft 7 in                                       |
| Reach at max. height  |     | 3 ft 3 in                                       |
| Breakout force with bucket  |     | 1880 daN  |
| Weight and dimensions   |     |   |
| Shipping mass (min. / max.)                                       |     | 5952 lb / 6393 lb                               |
| Ground clearance  | m4  | 11 in   |
| Wheelbase   | y   | 7 ft  |
| Overall length to carriage (with hitch)                           | l11 | 11 ft 5 in                                      |
| Front overhang  |     | 2 ft 6 in                                       |
| Overall width   | b1  | 4 ft 11 in                                      |
| Overall cab width   | b4  | 2 ft 2 in                                       |
| Overall height  | h17 | 6 ft 4 in                                       |
| Tilt-down angle   | a5  | 116 °   |
| Tilt-up angle   | a4  | 23 °  |
| External turning radius (over tyres)                              | Wa1 | 8 ft 7 in                                       |
| Standard tyres  |     | CAMSO - MPT 552 - 10.0/75-15.3 124A8            |
| Performances  |     |   |
| Lifting   |     | 8.80 s  |
| Lowering  |     | 7 s   |
| Extension   |     | 6.40 s  |
| Retraction  |     | 4.30 s  |
| Crowd   |     | 3.40 s  |
| Dump  |     | 2.60 s  |
| Engine  |     |   |
| Engine brand  |     | Yanmar  |
| Engine norm   |     | Stage V / Tier 4 final                          |
| Engine model  |     | 3TNV88C-DMU                                     |
| Number of cylinders - Capacity of cylinders                       |     | 3 - 100 in³                                     |
| I.C. Engine power rating / Power (kW)                             |     | 35.10 Hp / 26.20 kW                             |
| Max. torque / Engine rotation                                     |     | 105 Nm @1950 rpm                                |
| Drawbar pull (Laden)  |     | 2000 daN  |
| Reversible fan  |     | Option  |
| Engine cooling system   |     | 3 radiators (water + hydraulic oil + fuel)      |
| Transmission  |     |   |
| Transmission type   |     | Hydrostatic                                     |
| Number of gears (forward / reverse)                               |     | 2 / 2   |
| Max. travel speed (may vary according to applicable regulations)  |     | 16 mi/h   |
| Differential lock   |     | Limited slip differential on front & rear axles |
| Parking brake   |     | Automatic negative parking brake                |
| Service brake   |     | Hydraulic servo brake                           |
| Hydraulics  |     |   |
| Hydraulic pump type   |     | Gear pump                                       |
| Hydraulic flow - Pressure   |     | 48 l/min - 3408 PSI                             |
| Flow sharing distributor  |     | Standard  |
| Tank capacities   |     |   |
| Hydraulic oil   |     | 10 US gal                                       |
| Fuel tank   |     | 9 US gal  |
| Noise and vibration   |     |   |
| Noise at driving position (LpA) tested following NF EN 12053 norm |     | 76 dB   |
| Environmental noise (LwA)   |     | 104 dB  |
| Vibration to whole hand/arm                                       |     | < 2.50 m/s²                                     |
| Miscellaneous   |     |   |
| Safety cab homologation   |     | ROPS - FOPS cab (level 1)                       |
| Controls  |     | JSM   |

## ULM 415 H - Dimensional drawing

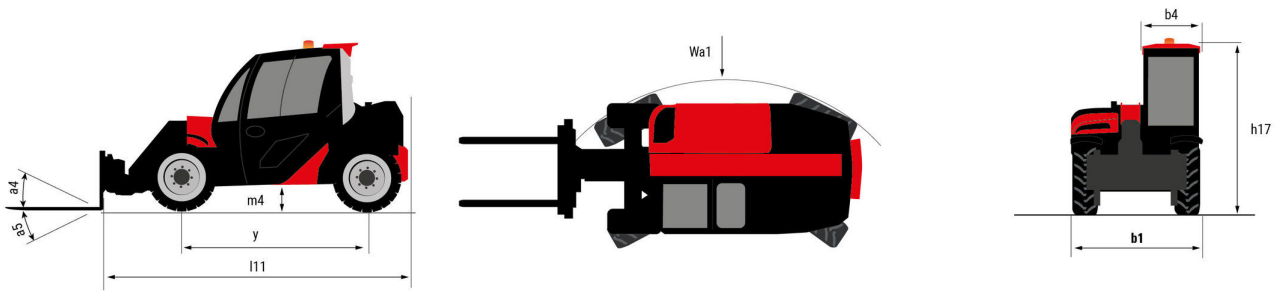

## ULM 415 H - Load chart

Machine on tyres with forks Imperial

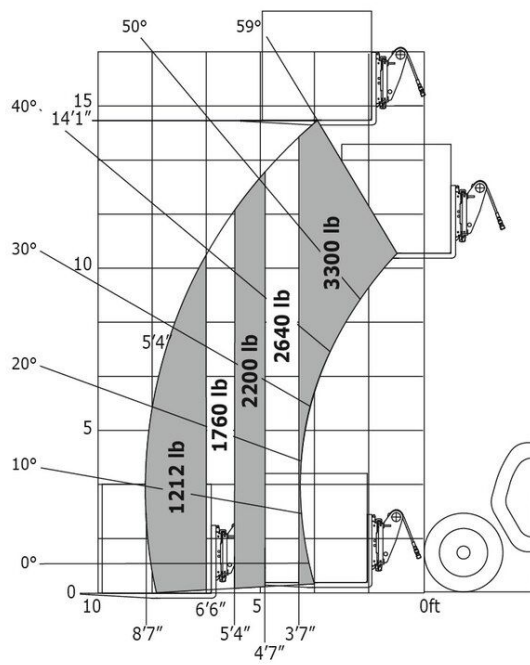



Siège Social

430 rue de l'Aubinière - 44150 Ancenis Cedex - France

Tel: +33(0)2 40 09 10 11 - Fax: +33 (0)2 40 09 10 97

[www.manitou.com](http://www.manitou.com)



This brochure describes versions and configuration options for Manitou products which may be fitted with different equipment. The equipment described in this brochure may be standard, optional or not available depending on version. Manitou reserves the right to change the specifications shown and described at any time and without prior warning. The manufacturer is not liable for the specifications given. For more information, contact your Manitou dealer. Non-contractual document. Product descriptions may differ from actual products. List of specifications is not comprehensive. The logos and visual identity of the company are the property of Manitou and may not be used without authorisation. All rights reserved. The photos and diagrams contained in this brochure are provided for information only.

MANITOU BF SA - Limited company with board of directors - Share capital: 39,668,399 euros - 857 802 508 RCS Nantes