

SPECIFICATIONS

HS120V **Skid Steer**



HD HYUNDAI
CONSTRUCTION EQUIPMENT

Net Power
69.7 HP (52.0 kW) / 2,200 rpm

Standard Bucket
0.58 yd³ (0.44 m³)

Rated Operating Capacity
2,690 lbs (1,220 kg)

Powered By Hyundai Performance Series Engine

ENGINE

Make/Model	Hyundai / 4HT14	
Emissions Certification	EPA Tier 4-Final	
Output	SAE J1995 Gross	73.6 hp (54.9 kW) / 2,400 rpm
	SAE J1349 Net	69.7 hp (52 kW) / 2,400 rpm
Displacement	148.6 cu in (2,435 cc)	
Number of Cylinders	4 cylinders	
Bore x Stroke	3.4" (87 mm) x 4.0" (102.4 mm)	
Aspiration	Turbocharged	
After treatment	DOC, DPF (No DEF)	

LOADER PERFORMANCE

Rated Operating Capacity ~35% tipping load	1,883 lbs (854 kg)	
Rated Operating Capacity ~50% tipping load	2,690 lbs (1,220 kg)	
Breakout Force	Bucket	6,327 lbf (2,870 kgf)
	Lift Arm	4,354 lbf (1,975 kgf)
Lift Arm Path	Vertical	
Control	ISO Pilot	

UNDERCARRIAGE

Standard tire size	12-16.5 12PR	
Travel Speed (1-Speed)	8.0 mph (12.8 km/h)	
Travel Speed (2-Speed)	Low	7.1 mph (11.5 km/h)
	High	19.4 mph (12.1 km/h)
Traction Force	8,494 lbf (3,853 kgf)	
Ground Clearance	8" (195 mm)	

HYDRAULIC SYSTEM (STANDARD)

Hydraulic Flow	21.9 gpm (82.9 lpm)
Hydraulic Pressure	3,335 psi (230 bar)

SERVICE REFILL CAPACITIES

Hydraulic System	10.0 gal (38 liters)
Engine oil	2.4 gal (9 liters)
Engine coolant (Radiator Included)	2.7 gal (10.4 liters)
Fuel tank	26.4 gal (100 liters)

OPERATOR STATION

Type	Open and Closed Cab
Sound Inside Closed Cab	80 dB
ROPS	ISO 3471
FOPS	ISO 3449

OPERATING WEIGHT

Open Cab	Coming Soon
Closed Cab	8,481 lbs (3,847 kg)

EQUIPMENT

STANDARD EQUIPMENT

- Enclosed Cab (ROPS/FOPS)
- Mechanical Suspension Seat
- 3 Retractable Seat Belt
- 12V Electric Outlet / USB Outlet
- Air Conditioner & Heater
- Horn / Backup Alarm
- Driving Lamp (Rear 2)
- Working Lamp (Front 2)
- Dial and Foot Throttle
- Bluetooth/USB Radio
- Two-Speed Travel
- Ride Control System
- Hydraulic Quick Coupler
- Heavy-duty Tire 12-16.5
- Boom Float Function
- Dual Air-Cleaner Elements
- Rearview Camera
- Bucket Self-leveling (Up Only)
- Rearview Mirror
- Multifunction Lever
- Interior Cab Light/Courtesy Light
- Telematics (Hi-MATE)
- 14-pin Coupler for Attachments
- Ride Control

OPTIONAL EQUIPMENT

- 2 Retractable Seat Belt*
 - Side Mirrors
 - License Lamp
 - Beacon Lamp
 - Driving Lamp (Front 2/Rear 2)
 - Working Lamp (Front 2/Rear 2)
 - Mechanical Quick Coupler*
 - Solid Tire Options
 - Additional Counterweight
 - Polycarbonate Front Door*
 - Fire Extinguisher
 - Tool Kit
 - ... and much more.
- * Factory Option

Hyundai will make product improvements from time to time to enhance customer experience and productivity.

SPECIFICATIONS HS120V

Powered By Hyundai Performance Series Engine

DIMENSIONS

All dimensions are approximate.

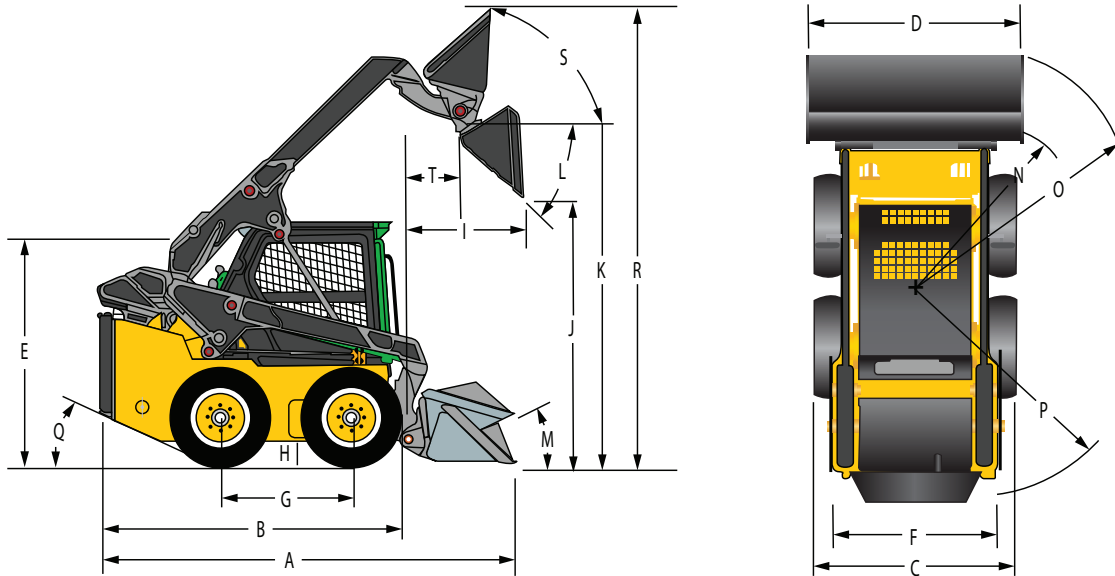

Unit: mm (ft-in)

DIMENSIONS		HS120V
A	Length w/bucket on ground	3,675 (12' 1")
B	Length w/o bucket	2,960 (9' 9")
C	Vehicle width over tire	1,820 (6' 0")
D	Width with bucket	1,890 (6' 2")
E	Height to top of cab	2,161 (7' 1")
F	Track tread	1,513 (5' 0")
G	Wheelbase	1,200 (3' 11")
H	Ground clearance	195 (0' 8")
I	Reach at max. lift and dump	949 (3' 1")
J	Height at max. lift and dump	2,473 (8' 1")
K	Hinge pin height at max. lift	3,215 (10' 7")
L	Max. dump angle	44.3°
M	Rollback angle on ground	29°
N	Turning radius from center - coupler	1,548 (5' 1")
O	Turning radius from center - bucket	2,170 (7' 1")
P	Turning radius from center - machine rear	1,850 (6' 1")
Q	Rear departure angle	25°
R	Max. overall height	4,068 (13' 4")
S	Rack back angle at max height	88.3°
T	Bucket pin reach at maximum lift	414 (1' 4")

