

Technical sheet :

2150 RT



Capacities		Imperial
Max. capacity	Q	6144 lb
Operating Weight		9901 lb
Operating Capacity at 35% Tipping Load		2150 lb
Operating Capacity At 50% Tipping Load		3071 lb
Tipping capacity		6144 lb
Weight and dimensions		
Overall Operating Height - Fully Raised	h27	168 in
Height to Hinge Pin – Fully Raised	h28	128 in
Reach - Fully Raised	dp1	34 in
Dump angle at full height	a5	39 °
Dump Height - Fully Raised	h29	98 in
Maximum Rollback Angle - Fully Raised	a4	102.50 °
Overall Height to Top of ROPS	h17	83 in
Overall length with bucket	l16	148 in
Departure angle	a2	29.20 °
Overall Length without Bucket	l1	116 in
Specified Height	h31	68 in
Reach at Specified Height	r4	31 in
Dump angle at specified height	a17	75 °
Maximum Rollback Angle at Ground	a13	30 °
Carry Position	d5	8 in
Maximum Rollback Angle at Carry Position	a14	31.60 °
Digging Position	h32	1 in
Angle of Departure with STD Counterweight		29.20 °
Ground clearance	m4	13 in
Track gauge	b10	52 in
Track Shoe Width	b20	18 in
Crawler base	y2	58 in
Overall width less bucket	b1	69 in
Bucket Width	e1	74 in
Clearance Radius - Front with Bucket	b18	95 in
Clearance Circle - Rear	wa1	65 in
Maximum rollback at specified height		66.80 °
Angle of Approach	a3	90 °
Grouser Height		1 in
Track Type / Track Rollers / Roller Type		Rubber / 5 / Steel
Performances		
Ground Speed - Single Speed		6 mi/h
Ground Speed - Two Speed		9 mi/h
Drawbar Pull/Tractive Effort		12132 lb
Bucket Breakout - Tilt Cylinder		6632 lb
Bucket Breakout - Lift Cylinder		6482 lb
Engine		
Engine brand		Yanmar
Engine model		TNV98CT-NMSL
Motor Type		Axial Piston with Planetary Gear Box Reduction
Gross Power (kW) / Power		53.70 kW / 2500 rpm
Net Power (kW) / Power		52.70 kW / 2500 rpm
Max. torque		294 Nm
Battery		12 V
Cold Cranking Amps at Temperature (CCA)		850 A
Alternator - Voltage / Ampere		14 V / 100 A
Hydraulics		
Standard flow - Auxiliary hydraulics		82.51 l/min
Tank capacities		
Oil Pan Capacity		3 US gal
Hydraulic tank capacity		14 US gal
Fuel tank		24 US gal
Coolant system capacity		4 US gal
Displacement / Number of cylinders		1 US gal / 4
Noise and vibration		
Environmental noise (LWA)		103 dB
Noise at driving position (LpA)		83 dB
Miscellaneous		
Ground Pressure		5 PSI

2150 RT - Dimensional drawing

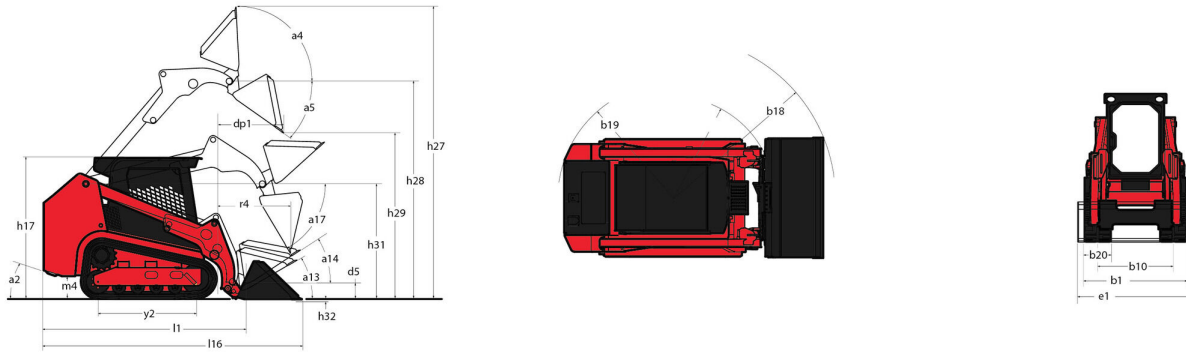

Equipment

Lifting function	
All-Tach® Attachment Mounting System	Standard
Auxiliary Hydraulics	Standard
Electronic Attachment Control - 14-Pin Connector	Optional
High-Flow Auxiliary Hydraulics	Optional
IdealTrax™ Automatic Track Tensioning System	Standard
Power-A-Tach® Attachment Mounting System	Optional
Motorization/Power	
Combination Radiator & Hydraulic Oil Cooler	Standard
Dual-Element Air Cleaner with Indicator	Standard
Engine Auto-Shutdown System	Standard
Glowplugs Starts Assist	Standard
Two-Speed Hydrostatic Drive System	Standard
Operator station	
Air suspension seat	Optional
Full-Suspension Seat	Standard
IdealAccess™ Fold-Up Door	Optional
Multi-Function Display Screen	Standard
Pressurized Cab Enclosure with A/C	Optional
ROPS/FOPS Level II Overhead Guard	Standard
Other options	
Selectable Self-Leveling Hydraulic Lift Action 4	Optional
Pneumatics	
Single Flange Front/Dual Flange Rear Idlers	Standard
Safety	
Anti-Vandalism Lock Provisions	Standard
Back-Up Alarm	Standard
Easy Manager	Standard
Engine Alert System with Error Display	Standard
Secondary functions	
Counterweight	Standard



Siège Social

430 rue de l'Aubinière - 44150 Ancenis Cedex - France

Tel: +33(0)2 40 09 10 11 - Fax: +33 (0)2 40 09 10 97

www.manitou.com



This brochure describes versions and configuration options for Manitou products which may be fitted with different equipment. The equipment described in this brochure may be standard, optional or not available depending on version. Manitou reserves the right to change the specifications shown and described at any time and without prior warning. The manufacturer is not liable for the specifications given. For more information, contact your Manitou dealer. Non-contractual document. Product descriptions may differ from actual products. List of specifications is not comprehensive. The logos and visual identity of the company are the property of Manitou and may not be used without authorisation. All rights reserved. The photos and diagrams contained in this brochure are provided for information only.

MANITOU BF SA - Limited company with board of directors - Share capital: 39,668,399 euros - 857 802 508 RCS Nantes