

# Hyundai R17Z-9A

## Specifications

**Net Power** 15.8 hp  
(11.8 kW) at 2,300 rpm

**Bucket Breakout Force**  
(ISO) 1,580 kgf / 3,490 lbf

**Operating Weight**  
1,780 kg (3,920 lb)

**Arm Digging Force**  
(ISO) 870 kgf / 1,920 lbf

### ENGINE

MODEL		KUBOTA D902	
Type		T4 final, 3 cylinder diesel	
Rated flywheel horsepower	SAE	J1995 (gross)	16.8 hp (12.5kw) @ 2,300 rpm
		J1349 (net)	15.8 hp (11.8kw) @ 2,300 rpm
Max. torque		5.6 kgf·m (40.5 lbf·ft) at 1,900 rpm	
Bore X stroke		72 mm (2.83") x 73.6 mm (2.90")	
Piston displacement		898 cc (54.79 in <sup>3</sup> )	
Battery		1 x 12 V x 45 Ah	
Starting motor		12 V – 1.2 kW	
Alternator		12 V – 40 Amp	

### HYDRAULIC SYSTEM

MAIN PUMP	
Type	Variable displacement piston pumps + gear pump
Max. flow	2 x 18.8 ℓ/min (5 gpm) + 11.3 ℓ/min (3 gpm) + 6.8 ℓ/min (1.8 gpm) at 2,500 rpm
Sub-pump for pilot circuit	Gear pump

### CROSS-SENSING AND FUEL-SAVING PUMP SYSTEM

HYDRAULIC MOTORS	
Travel	Two-speed axial piston motor with counter balance valve and parking brake
Swing	Axial piston motor with automatic brake

### RELIEF VALVE SETTING

Implement circuits	210 kgf/cm <sup>2</sup> (2,990 psi)
Travel circuit	210 kgf/cm <sup>2</sup> (2,990 psi)
Swing circuit	135 kgf/cm <sup>2</sup> (1,920 psi)
Pilot circuit	30 kgf/cm <sup>2</sup> (430 psi)
Service valve	Installed

### HYDRAULIC CYLINDERS

No. of cylinders bore X stroke	Boom: 60 x 440 mm (2.3" x 17.3")
	Arm: 60 x 353 mm (2.3" x 13.8")
	Bucket: 55 x 320 mm (2.16" x 12.59")
	Boom swing: 55 x 355 mm (2.16" x 13.97")
	Dozer blade: 65 x 115 mm (2.6" x 4.5")
Extension: 55 x 310 mm (2.16" x 12.2")	

### TRAVEL SYSTEM

Drive method	Full hydrostatic type
Drive motor	Axial piston motor, in-shoe design
Reduction system	Planetary reduction gear
Max. drawbar pull	1,420 kgf (3,130 lbf)
Max. travel speed (high) / (low)	2.2 km/hr (1.4 mph) / 4.1 km/hr (2.5 mph)
Gradeability	30° (58%)
Parking brake	Multi-wet disc

### CONTROLS

Pilot-pressure-operated joysticks and pedals with detachable lever provide almost effortless and fatigueless operation.

Pilot control	Two joysticks with one safety lever (LH): Arm swing, boom swing (RH): Boom and bucket (ISO)
Traveling and steering	Two levers with pedals
Engine throttle	Mechanical, cable type

### SWING SYSTEM

Swing motor	Orbit motor
Swing bearing lubrication	Lubricated with drain
Swing speed	9.5 rpm

### COOLANT AND LUBRICANT CAPACITY

(Refilling)	liter	gal
Fuel tank	20	5.3
Engine coolant	3.5	0.9
Engine oil	3.7	1.0
Hydraulic tank	13	3.4
Hydraulic system	23	6.1

### WEIGHT (APPROXIMATE)

Operating weight, including 1,800 mm (5' 11") boom, 960 mm (3' 2") arm, SAE heaped 0.04 m<sup>3</sup> (0.05 yd<sup>3</sup>) excavator bucket, 230 mm (9") rubber track, lubricant, coolant, full fuel tank, hydraulic tank, 268 kg (590 lb) counterweight and the standard equipment.

Operating weight (canopy)	1,780 kg (3,920 lb)
Ground pressure (canopy)	0.26 kg/cm <sup>2</sup> (3.70 psi)

### UNDERCARRIAGE

Center frame is integrally welded with reinforced box-section track frames. The undercarriage includes lubricated rollers, track adjusters with shock absorbing springs and sprockets, and rubber shoes.

Track frame	Variable undercarriage
No. of track roller on each side	3

## R17Z-9A Lifting Capacity ISO Condition 2

Rating over front Rating over side or 360 degree

Boom: 1.80 m (5' 11") / Arm: 0.96 m (3' 2") / Bucket: 0.04 m<sup>3</sup> (0.05 yd<sup>3</sup>) SAE heaped / Dozer down / Rubber track 230 mm (9") / Counterweight 268 kg (590 lb)

Lift-point height m (ft)	Lift-point radius										At max. reach Capacity		Reach m(ft)	
	1.0 m (3.3 ft)		1.5 m (4.9 ft)		2.0 m (6.6 ft)		2.5 m (8.2 ft)		3.0 m (9.8 ft)		Capacity	Reach		
2.5 m 8.2 ft	kg							*360	*360			*340	*340	2.70
	lb							*800	*800			*740	*740	(8.9)
2.0 m 6.6 ft	kg							*370	*370	*370	290	*320	280	3.04
	lb							*830	*830	*830	640	*700	620	(10.0)
1.5 m 4.9 ft	kg		*730	*730	*510	*510	*430	380	*390	290	*320	250	3.25	
	lb		*1,610	*1,610	*1,130	*1,130	*940	840	*860	630	*700	550	(10.6)	
1.0 m 3.3 ft	kg				*680	510	*500	370	*420	280	*330	240	3.34	
	lb				*1,500	1,130	*1,100	810	*920	620	*730	520	(11.0)	
0.5 m 1.6 ft	kg				*800	490	*560	360	*450	270	*360	230	3.34	
	lb				*1,770	1,080	*1,240	780	*990	600	*790	520	(10.9)	
0.0 m 0.0 ft	kg		*580	*580	*830	480	*590	350	*460	270	*410	240	3.24	
	lb		*1,290	*1,290	*1,830	1,060	*1,310	770	*1,010	590	*900	530	(10.6)	
-0.5 m -1.6 ft	kg	*720	*720	*1,000	770	*790	480	*570	350	*430	270	*420	270	3.03
	lb	*1,580	*1,580	*2,210	1,700	*1,740	1,060	*1,260	760	*940	590	*920	590	(9.9)
-1.0 m -3.3 ft	kg	*1,110	*1,110	*970	780	*680	480	*490	350		*420	320	2.68	
	lb	*2,440	*2,440	*2,140	1,720	*1,500	1,070	*1,070	770		*930	700	(8.8)	
-1.5 m -4.9 ft	kg			*630	*630	*430	*430				*400	*400	2.08	
	lb			*1,390	*1,390	*950	*950				*870	*870	(6.8)	

- Notes:
- Lifting capacities are based on ISO 10567.
  - Lifting capacities of the 9A Series does not exceed 75% of tipping load with the machine on firm, level ground or 87% of full hydraulic capacity.
  - The lift-point is a hook (standard equipment) located on the back of the bucket.
  - (\*) indicates load limited by hydraulic capacity.

# Dimensions & Working Range

## R17Z-9A DIMENSIONS

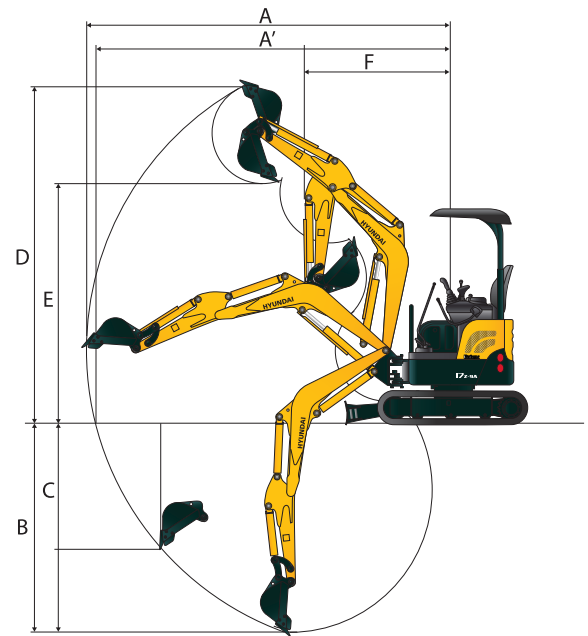
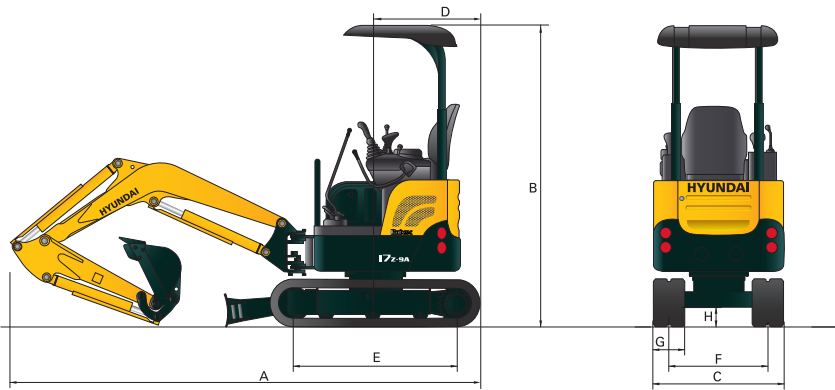

### R17Z-9A DIMENSIONS

	mm (ft-in)		
<b>A</b> Overall length	3,480 (11'4")	<b>E</b> Tumbler distance	1,230 (4'0")
<b>B</b> Overall height	2,320 (7'7")	<b>F</b> Track gauge	760~1,070 (2'6"-~3'5")
<b>C</b> Overall width	990~1,300 (3'2"- 4'2")	<b>G</b> Track shoe width	230 (0'9")
<b>D</b> Tail swing radius	645 (2'11") 720 (2'3") (With additional counterweight)	<b>H</b> Ground clearance	440 mm (1'5")

### R17Z-9A WORKING RANGE

	mm (ft-in)	
Boom length	1,800 (5'11")	
Arm length	960 (3'2")	1,120 (3'8")
<b>A</b> Max. digging reach	3,900 (12'7")	4,030 (13'2")
<b>A'</b> Max. digging reach on ground	3,800 (12'4")	3,940 (12'9")
<b>B</b> Max. digging depth	2,200 (7'2")	2,350 (7'7")
<b>C</b> Max. vertical wall digging depth	1,320 (4'3")	1,460 (6'3")
<b>D</b> Max. digging height	3,580 (11'7")	3,680 (12'0")
<b>E</b> Max. dumping height	2,570 (8'4")	2,670 (8'7")
<b>F</b> Min. swing radius	1,570 (5'1")	1,600 (5'2")

## STANDARD EQUIPMENT

Canopy TOPS ISO 12117  
(ROPS ISO 12117-2)  
FOG ISO 10262 Level I  
(FOPS ISO 3449 Level I)

### Centralized monitoring

- Gauges
- Fuel-level gauge
- Engine coolant temperature gauge

### Proportional control switch

### Warning indicator

- Quick clamp
- Engine oil pressure
- Engine coolant temperature
- Preheat
- Low battery
- Fuel empty

### One key

Mechanical suspension seat with seat belt

Console box tilting system (LH)

One front working light

Electric horn

### Battery (1 x 12 V x 45 AH)

Battery master switch

Removable reservoir tank

Water separator, fuel line

Mono boom (1.80 m / 5' 11")

Arm (0.96 m / 3' 2")

Rubber track shoes (230 mm / 9")

Double-acting piping

Travel alarm

Pattern-change lever

Quick coupler and piping

Additional counterweight (414 kg / 177 lbs)

Hyundai bucket (0.04 m<sup>3</sup> / 0.05 yd<sup>3</sup>)

## OPTIONAL EQUIPMENT

### Accumulator

Long arm (1.12 m / 3' 8")



www.hceamericas.com

6100 Atlantic Blvd., Norcross, GA 30071

TEL (678) 823 7777 FAX (678) 823 7778