

SPECIFICATIONS

HX260AL

Powered By Cummins Performance Series Engine

Net Power
169kW (227hp)
at 2,000rpm

Standard Bucket
1.17 m³ (1.53 yd³)

Operating Weight
27,000 (59,520) –
27,910 (61,530)



ENGINE	
Maker / Model	Cummins B6.7
Type	4 cylinder, watercooled, 4-cycle, turbocharged charge aircooled, direct injection, electronic controlled diesel engine
Gross Power	173kW (232hp) at 2,000rpm
Net Power	169kW (227hp) at 2,000rpm
Max. Power	173kW (232hp) at 2,000rpm
Peak Torque	949 N·m (700 lb-ft) at 1,500 rpm
Displacement	6.7 l (408 cu in)

HYDRAULIC SYSTEM	
MAIN PUMP	
Type	Variable displacement tandem axis piston pumps
Max. Flow	2 × 221 l /min
Sub-Pump for Pilot Circuit	Gear pump

Cross-sensing and fuel saving pump system.

AUXILIARY PRESSURE			
2 Way	Flow (l/min)	26.4 gpm / (100 lpm)	
	Pressure (bar)	2,611 psi / (180 bar)	
Rotating	Flow (l/min)	15.9 gpm / (60 lpm)	
	Pressure (bar)	4,062 psi / (280 bar)	

HYDRAULIC MOTORS	
Travel	Two speed axial pistons motor with brake valve and parking brake
Swing	Axial piston motor with automatic brake

RELIEF VALVE SETTING	
Implement Circuits	350 kgf/cm ² (4,980 psi)
Travel	350 kgf/cm ² (4,980 psi)
Power Boost (Boom, Arm, Bucket)	380 kgf/cm ² (5,400 psi)
Swing Circuit	300 kgf/cm ² (4,270 psi)
Pilot Circuit	40 kgf/cm ² (570 psi)
Service Valve	Installed

HYDRAULIC CYLINDERS	
Boom cylinder	∅135×1,395 mm
Arm cylinder	∅145×1,620 mm
Arm cylinder (2-piece boom)	∅145×1,620 mm
Adjust cylinder (2-piece boom)	∅160×1,230 mm
Bucket cylinder	∅130×1,185 mm

* Hyundai Bio Hydraulic Oil (HBHO) available.

DRIVES & BRAKES	
Drive Method	Fully Hydrostatic Type
Drive Motor	Axial Piston Motor, In-Shoe Design
Reduction System	Planetary Reduction Gear
Max. Drawbar Pull	22,190 kgf (48,930 lbf)
Max. Travel Speed (High / Low)	5.6 km/hr (3.5 mph) / 3.3 km/hr (2.0 mph)
Gradeability	35° (70%)
Parking Brake	Multi Wet Disc

CONTROL	
Pilot pressure operated joysticks and pedals with detachable lever provide almost effortless and fatigueless operation.	
Pilot Control	Two Joysticks with One Safety Lever (LH): Swing and Arm (RH): Boom and Bucket
Traveling And Steering	Two Levers With Pedals
Engine Throttle	Electric, Dial Type

OPERATING WEIGHT (APPROXIMATE)

Operating weight, including 5.85m (19' 2") boom, 3.05m (10' 0") arm, SAE heaped 1.17 m³ (1.53 yd³) bucket, lubricant, coolant, full fuel tank, full hydraulic tank, and all standard equipments.

OPERATING WEIGHT

Type	Width mm (in)		Operating Weight		Ground Pressure
			kg (lb)		kgf/cm ² (psi)
Triple Grouser	600 (24")	HX260AL	27,000 (59,520)		0.55 (7.81)
	700 (28")	HX260AL	27,310 (60,210)		0.48 (6.77)
	800 (32")	HX260AL	27,600 (60,850)		0.42 (5.99)
	900 (36")	HX260AL	27,910 (61,530)		0.38 (5.39)

SWING SYSTEM

Swing Motor	Fixed Displacement Axial Piston Motor
Swing Reduction	Planetary Gear Reduction
Swing Bearing Lubrication	Grease-Bathed
Swing Brake	Multi Wet Disc
Swing Speed	11.2 rpm

COOLANT & LUBRICANT CAPACITY

	LITER	US gal
Fuel Tank	450	118.9
Engine Coolant	40	10.6
Engine Oil	23.1	6.1
Swing Device	7	1.8
Final Drive (Each)	6	1.6
Hydraulic System (Including Tank)	275	72.6
Hydraulic Tank	160	42.3
DEF/AdBlue®	48	12.6

UNDERCARRIAGE

The X-leg type center frame is integrally welded with reinforced box-section track frames. The undercarriage includes lubricated rollers, idlers, track adjusters with shock absorbing springs and sprockets, and a track chain with double or triple grouser shoes.

Center Frame	X - Leg Type	
	Pentagonal Box Type	
No. of Shoes on Each Side	51 EA	
No. of Carrier Roller on Each Side	2 EA	
No. of Track Roller on Each Side	9 EA	
No. of Rail Guard on Each Side	2 EA	

CAB NOISE LEVEL

Guaranteed noise level presented below can be differed depending on a range of factors such as operating condition, speed of a cooling fan, types of engine and so forth. Hearing protection shall be necessary if an operator is working in the improperly aintained cabin or exposed to a noisy environment by leaving doors and/or windows open. With cooling fan speed at maximum value:

Operator sound pressure level (ISO 6396:2008)	70 dB(A)
Exterior sound power level (ISO 6395:2008)	98 dB(A)

* Distance of 15 m (49.2 ft), moving forward in second gear ratio

SPECIFICATIONS HX260A L

Powered By Cummins Performance Series Engine

HX260AL DIMENSIONS

Unit: mm (ft.-in)

5.85 m (19' 2") BOOM and 3.05 m (10' 0"), 2.1 m (6' 11"), 2.5 m (8' 2"), 3.6 m (11' 10")

A	Tumbler Distance	3,830 (12' 7")
B	Overall Length of Crawler	4,640 (15' 3")
C	Ground Clearance of Counterweight	1,110 (3' 8")
D	Tail Swing Radius	3,085 (10' 1")
D'	Rear-End Length	2,990 (9' 10")
E	Overall Width of Upperstructure	2,840 (9' 4")
F	Overall Height of Cab	3,050 (10' 0")
G	Min. Ground Clearance	480 (1' 7")
H	Track Gauge	2,580 (8' 6")
I	Overall Height of Guardrail	3,260 (10' 8")

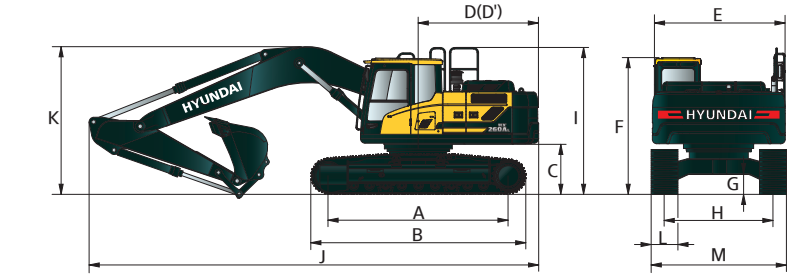

Boom length	5.85 (19' 2")			
Arm length	3.05 (10' 0")	2.1 (6' 11")	2.5 (8' 2")	3.6 (11' 10")
J Overall length	10,040 (32' 11")	10,170 (33' 4")	10,120 (33' 2")	10,030 (32' 11")
K Overall height of boom	3,220 (10' 7")	3,530 (11' 7")	3,590 (11' 9")	3,590 (11' 9")
L Track shoe width	600 (1' 12")	700 (2' 4")	800 (2' 7")	900 (2' 11")
M Overall Width (w/Foot Board)	3,180 (10' 5")	3,280 (10' 9")	3,380 (11' 1")	3,480 (11' 5")

HX260AL WORKING RANGE

Unit : mm (ft.-in)

Boom length	5.85 (19' 2")			
Arm length	3.05 (10' 0")	2.10 (6' 11")	2.50 (8' 2")	3.60 (11' 10")
A Max. digging reach	10,360 (34' 0")	9,560 (31' 4")	9,870 (32' 5")	10,870 (35' 8")
A' Max. digging reach on ground	10,190 (33' 5")	9,370 (30' 9")	9,690 (31' 9")	10,710 (35' 2")
B Max. digging depth	7,010 (23' 0")	6,060 (19' 11")	6,460 (21' 2")	7,560 (24' 10")
B' Max. digging depth (8' level)	6,850 (22' 6")	5,850 (19' 2")	6,280 (20' 7")	7,420 (24' 4")
C Max. vertical wall digging depth	6,170 (20' 3")	5,520 (18' 1")	5,680 (18' 8")	6,860 (22' 6")
D Max. digging height	10,290 (33' 9")	9,950 (32' 8")	10,020 (32' 10")	10,560 (32' 7")
E Max. dumping height	7,150 (23' 5")	6,800 (22' 4")	6,900 (22' 8")	7,430 (22' 6")
F Min. swing radius	3,450 (11' 4")	3,840 (12' 7")	3,190 (10' 6")	3,150 (10' 4")

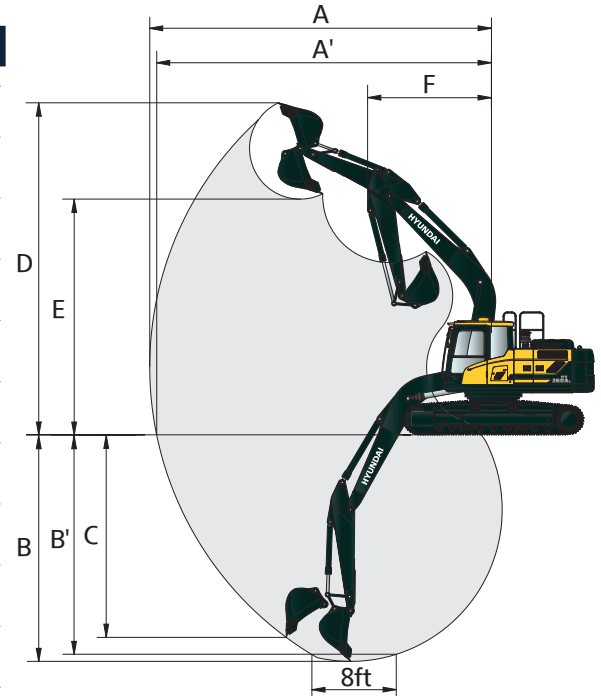

HX260AL DIGGING FORCE

Boom	Length	mm (ft.in)	5,850 (19' 2")			
	Weight	kg (lb)	2,460 (5,420)			
Arm	Length	mm (ft.in)	2,100 (6' 11")	2,500 (8' 2")	3,050 (10' 0")	3,600 (11' 10")
	Weight	kg (lb)	1,420 (3,130)	1,450 (3,200)	1,540 (3,400)	1,600 (3,530)
Bucket Digging Force	SAE	kN	153.1 [166.1]	153.6 [167.2]	154.0 [167.2]	154.1 [167.2]
		kgf	15,600 [16,940]	15,700 [17,050]	15,700 [17,050]	15,700 [17,050]
		lbf	34,403 [37,350]	34,522 [37,590]	34,603 [37,590]	34,638 [37,590]
	ISO	kN	177.2 [192.7]	177.8 [192.7]	178.2 [193.8]	178.4 [193.8]
		kgf	18,100 [19,650]	18,100 [19,650]	18,200 [19,760]	18,200 [19,760]
		lbf	39,819 [43,320]	39,957 [43,320]	40,051 [43,560]	40,092 [43,560]
Arm Crowd Force	SAE	kN	159.2 [172.5]	134.3 [145.8]	113.3 [122.5]	103.1 [111.8]
		kgf	16,200 [17,590]	13,700 [14,870]	11,500 [12,490]	10,500 [11,400]
		lbf	35,777 [38,780]	30,188 [32,780]	25,461 [27,540]	23,170 [25,130]
	ISO	kN	167.7 [182.1]	140.8 [153.3]	118.2 [127.8]	107.0 [116.0]
		kgf	17,100 [18,570]	14,400 [15,630]	12,000 [13,030]	10,900 [11,830]
		lbf	37,698 [40,940]	31,651 [34,460]	26,553 [28,730]	24,056 [26,080]

[]: Power Boost

Note : Boom weight includes arm cylinder, piping, and pin
Arm weight includes bucket cylinder, linkage, and pin

SPECIFICATIONS HX260A L

Powered By Cummins Performance Series Engine

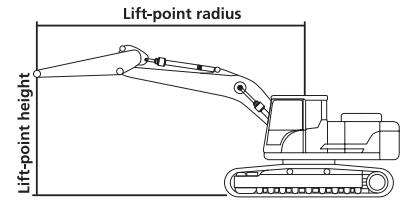

Lifting Capacity

Boom: 5.85 m (19' 2")

Arm: 3.05 m (10')

Shoe 800 mm (32") triple grouser

CWT 4,600 kg (10,141 lb)

Capacities based on North American Standard Configuration in accordance with ISO condition 2 standard.

Rating over front

Rating over side or 360 degree

Lift-point height m (ft)		Lift-point radius										At max. reach		
		1.5 m (4.9 ft)		3.0 m (9.8 ft)		4.5 m (14.8 ft)		6.0 m (19.7 ft)		7.5 m (24.6 ft)		Capacity		Reach
														m (ft)
7.5 m	kg							*5,640	*5,640			*4,010	*4,010	6.66
24.6 ft	lb							*12,430	*12,430			*8,840	*8,840	(21.8)
6.0 m	kg							*5,760	*5,760	*4,710	*4,710	*3,770	*3,770	7.70
19.7 ft	lb							*12,700	*12,700	*10,380	*10,380	*8,310	*8,310	(25.3)
4.5 m	kg					*7,530	*7,530	*6,560	*6,560	*6,130	4,780	*3,730	*3,730	8.34
14.8 ft	lb					*16,600	*16,600	*14,460	*14,460	*13,510	10,540	*8,220	*8,220	(27.4)
3.0 m	kg					*10,040	10,020	7,740	6,490	*6,690	4,610	*3,830	3,640	8.67
9.8 ft	lb					*22,130	22,090	17,060	14,310	*14,750	10,160	*8,440	8,020	(28.5)
1.5 m	kg					*12,350	9,290	8,940	6,140	6,790	4,430	*4,100	3,510	8.74
4.9 ft	lb					*27,230	20,480	19,710	13,540	14,970	9,770	*9,040	7,740	(28.7)
Ground Line	kg			*6,350	*6,350	*13,640	8,910	9,310	5,890	6,640	4,300	*4,570	3,580	8.53
	lb			*14,000	*14,000	*30,070	19,640	12,530	12,990	14,640	9,480	*10,080	7,890	(28.0)
-1.5 m	kg	*7,170	*7,170	*11,190	*11,190	*13,910	8,790	9,180	5,780	6,580	4,240	*5,400	3,860	8.04
-4.9 ft	lb	*15,810	*15,810	*24,670	*24,670	*30,670	19,380	20,240	12,740	14,510	9,350	*11,900	8,510	(26.4)
-3.0 m	kg	*12,120	*12,120	*17,600	*17,600	*13,260	8,860	9,220	5,810			7,040	4,540	7.21
-9.8 ft	lb	*26,720	*26,720	*38,800	*38,800	*29,230	19,530	20,330	12,810			15,520	10,010	(23.7)
-4.5 m	kg			*15,990	*15,990	*11,320	9,130					*8,170	6,210	5.88
-14.8 ft	lb			*35,250	*35,250	*24,960	20,130					*18,010	13,690	(19.3)

NOTES:

- Lifting capacities are based on ISO 10567.
- Lifting capacity of the HX Series does not exceed 75% of tipping load with the machine on firm, level ground or 87% of full hydraulic capacity.
- The Lift-point is bucket pivot mounting pin on the arm (without bucket mass).
- (*) indicates load limited by hydraulic capacity.



ENGINE	STD	OPT
Cummins B6.7	●	
HYDRAULIC SYSTEM		
Electric Positive Flow Control (EPFC)		
3-Power Mode, 2-Work Mode, User Mode	●	
Variable Power Control	●	
Pump Flow Control	●	
Attachment Mode Flow Control	●	
Engine Auto Idle	●	
Electronic Swing Parking Brake		●
Engine Auto Shutdown Control	●	
Electronic Fan Control	●	
Hyundai Bio Hydraulic oil (HBHO)		●
CAB & INTERIOR		
ISO Standard cabin		
Rise-Up Type Windshield Wiper	●	
Radio / USB Player	●	
Handsfree Mobile Phone System with USB	●	
12V Power Outlet (24V DC to 12V DC converter)	●	
Electric Horn	●	
All-Weather Steel Cab with 360° Visibility	●	
Safety Glass - Tempered Glass	●	
Safety Glass - Laminated Glass, Front Window & Glass		●
Sliding Fold-In Front Window	●	
Sliding Side Window (LH)	●	
Lockable Door	●	
Hot & Cool Box	●	
Storage Compartment	●	
Ashtray	●	
Transparent Cabin Roof-Cover	●	
Sun Visor	●	
Door And Cab Locks, One Key	●	
Mechanical Suspension Seat With Heater	●	
Pilot-Operated Slidable Joystick	●	
Console Box Height Adjust System	●	
Automatic climate control		
Air Conditioner & Heater	●	
Defroster	●	
Starting Aid (Air Grid Heater) for Cold Weather	●	
Centralized monitoring		
8" LCD Display	●	
Engine Speed or Trip Meter / Accel.	●	
Engine Coolant Temperature Gauge	●	
Max Power	●	
Low Speed / High Speed	●	
Auto Idle	●	
Overload	●	
Check Engine	●	
Air Cleaner Clogging	●	
Indicators	●	
ECO Gauges	●	
Fuel Level Gauge	●	
Hyd. Oil Temperature Gauge	●	
Warnings	●	
Communication Error	●	
Low Battery	●	
Clock	●	
Cabin Lights	●	
Cabin Front Window Rain Guard		●
Cabin Roof-Steel Cover		●
Seat		
Adjustable Air Suspension Seat With Heater	●	
Cabin FOG (ISO 10262) Level 2		
FOG (Falling Object Protective Structure)-ISO 10262 Level 2		●
Cabin ROPS		
ROPS (Roll Over Protective Structures)-ISO 1211 7-2	●	

SAFETY	STD	OPT
Battery Master Switch	●	
Rearview Camera	●	
AAVM (Advanced Around View Monitoring)		●
Four Front Working Lights (2 Boom Mounted, 2 Front Frame Mounted)	●	
Travel Alarm	●	
Rear Work Lamp		●
Beacon Lamp		●
Automatic Swing Brake	●	
Boom Holding System	●	
Arm Holding System	●	
Safety Lock Valve For Boom Cylinder With Overload Warning Device		●
Safety Lock Valve For Arm Cylinder		●
Swing Lock System		●
Three Outside Rearview Mirror	●	
Front Guard - Wire Net		●
ATTACHMENT		
Booms		
5.85 m, 19' 2"	●	
Arms		
2.10 m, 6' 11"		●
2.50 m, 8' 2"		●
3.05 m, 10' 0"	●	
3.60 m, 11' 10"		●
OTHER		
Removable Clean-Out Dust Net For Cooler	●	
Removable Reservoir Tank	●	
Fuel Warmer		●
Self-Diagnostics System	●	
Hi MATE (Remote Management System)	●	
Batteries (2 × 12 V × 100 AH)	●	
Fuel Filler Pump (50 l /min)		●
Single-Acting Piping Kit (Breaker, Etc.)		●
Double-Acting Piping Kit (Clamshell, Etc.)		●
2 way Proportional RCV & Pedal control selection	●	
Rotating Piping Kit		●
Quick Coupler Piping	●	
Quick Coupler		●
One Pedal Straight Travel System	●	
Accumulator For Lowering Work Equipment	●	
Pattern Change Valve (2 Patterns)	●	
Fine Swing Control System		●
Tool Kit		●
UNDERCARRIAGE		
Lower Frame Under Cover (Additional)		●
Lower Frame Under Cover (Normal)	●	
Track Shoes		●
Triple Grousers Shoes (600 mm, 1' 12")		
Triple Grousers Shoe (700 mm, 2' 4")		●
Triple Grousers Shoe (800 mm, 2' 7")	●	
Triple Grousers Shoe (900 mm, 2' 11")		●
Track Rail Guard	●	

* Standard and optional equipment may vary. Contact your Hyundai dealer for more information. The machine may vary according to International standards.

* The photos may include attachments and optional equipment that are not available in your area.

* Materials and specifications are subject to change without advance notice.

* All imperial measurements rounded off to the nearest pound or inch.