

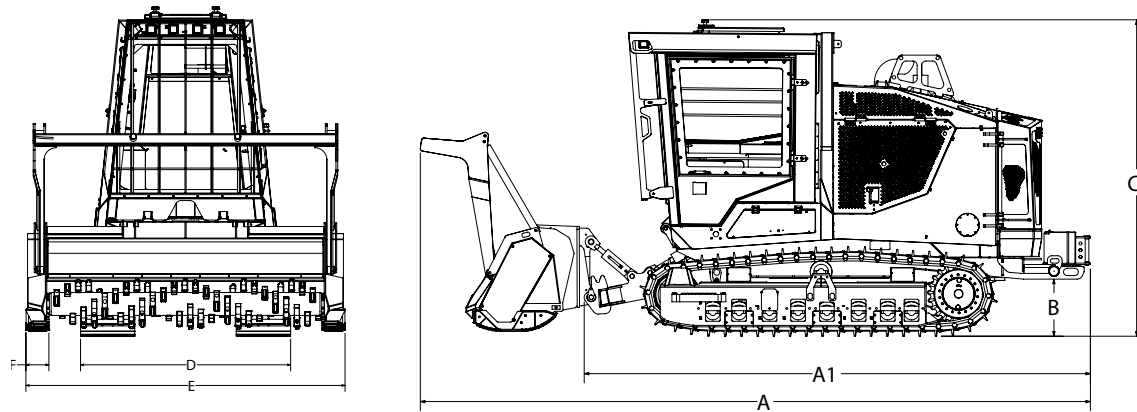

TWISTER II C175

SPECIFICATIONS

ENGINE		UNDERCARRIAGE & GROUND PRESSURE	
Manufacturer & Model	CUMMINS B4.5 Stage V	Chain Type & Size	Sealed and greased, FL4
Cylinders & Displacement	4 cylinders / 275 CID (4.5 L)	Track Shoe & Rollers	18 in (460 mm) single grouser with mud hole, dozer type rollers
Peak Power at 2,500 rpm (SAE J1995)	173 hp (129 kW)	Ground Pressure (Crawler only, 18 in pads)	4.34 psi (0.29 kg/cm ²)
Net Peak Torque	576 ft-lbf (780 Nm)	Weight (Crawler only, 18 in pads)	16 270 lb (7 396 kg)
Fan	Automatic variable pitch, reversible	TOP SPEED	
HYDRAULICS		Motor	Two speed hydraulic motors
Pump System	4	Speed	Variable speed from 0 to 3.85 mph (0 to 6.2 km/h)
Filtration	10 Microns	STANDARD CHARACTERISTICS	
ELECTRICAL		<ul style="list-style-type: none"> - Push button cab lift with manual override - Backup camera - AM/FM/Bluetooth radio - Hydraulic oil filler pump - Air suspension seat - ROPS/FOPS/OPS Certification - 12 Volts DC outlet - Electric system with breakers in dash for easy troubleshoot 	
Voltage	12 Volts		
Standard Light	8 LED type (4 Front, 2 Side, 2 Rear)		
SERVICEABILITY			
Fuel Tank	78.5 gal US (297 L)		
Hydraulic Reservoir (80% full)	29 gal US (110 L)		
Cooling System	7.13 gal US (27 L)		



MACHINE DIMENSIONS

A - Overall Length with mulcher head (*): 222.6 in (565 cm)

A1 - Overall Length: 170.6 in (433 cm)

B - Ground Clearance: 17.13 in (43 cm)

C - Overall Height: 107.63 in (273 cm)

D - Standard - Overall width: 76.5 in (194 cm)

D - Seismic - Overall width: 68.5 in (174 cm)

E - Mulching head overall width (*): 95 in (241 cm)

(E-2F) - Mulching head working width (*): 81 in (206 cm)

(*) - Specs for FAE 140U200 head; Dimensions will vary if other type of head is selected

CMI Mulching inc.
1200 Chemin Herman-Lavigne | Saint-Cyrille-De-Wendover, QC, Canada J1Z 1S4
819 397-2288 | www.cmimulching.com

C.M.I. reserves the right to change specifications, design and price of products described in this literature without notice. C.M.I. and C175 are registered trademarks of C.M.I. Danri inc. Printed in Canada.

TWISTER II C175



The Mulching Specialists

PERFORMANCE | RELIABILITY | SIMPLICITY

TWISTER II C175

IMPROVED FEATURES ALONG WITH CMI'S RELIABLE SIMPLICITY



RESETTABLE BREAKERS ON DASH PANEL MAKING IT EASY ON TROUBLE SHOOTING

NEW DIGITAL SCREEN FOR EASY DATA ACCESS AND DIAGNOSTIC

12 VOLTS DC OUTLET

AM/FM/BLUETOOTH RADIO

AIR SUSPENSION SEAT

GREAT VISIBILITY

PUSH BUTTON CAB TILT FOR EASY ACCESS TO COMPONENTS & HYDRAULIC OIL FILLING PUMP

PRESSURISED CABIN WITH INTEGRATED HEAVY DUTY PRE-CLEANER



CLEAR THROUGH BOTTOM WITH HIGH GROUND CLEARANCE AND NO CROSS BEAM

STANDARD 15 000 LB WINCH

HIGH TRACTION TORQUE ALLOWING C175 TO CLIMB HILLS LIKE NO OTHER

**HIGHEST TORQUE AND
LOWEST WEIGHT IN IT'S CLASS.
PROVEN AND TIME TESTED
CMI RELIABILITY.**