



MULCHERS FOR
EXCAVATORS



M450e

The M450e is a lightweight mulcher for 6-15 ton excavators. The weight is strongly optimized and allows easy handling. In particular, the installed gear motor allows simplified mounting on various excavators as well as rapid changing of carrier units, without installation of additional drain lines.

Benefits for you:

- + Plug & Mulch
- + Lightweight
- + Simple robust design



Plug & Mulch

No extra drain line is required. Freewheel and pressure protection are already integrated into the motor.



Universal connection

Using the adapter plate, the mulcher can be mounted on every position of the excavator arm.



Stall protection

Counter blades prevent large objects infiltrating and stalling the rotor.



Wear plates

Can be easily replaced and protect the particularly wear-prone areas in the housing.

| TECHNICAL SPECIFICATION | M450E-900 | M450E-1090 |
|-------------------------|----------------|----------------|
| Working width in [mm] | 35 [900] | 43 [1100] |
| Overall width in [mm] | 49 [1236] | 57 [1441] |
| Volume flow gpm [l/min] | 16-29 [60-110] | 16-29 [60-110] |
| Weight lbs [kg]* | 992 [450] | 1091 [495] |
| Tools | 20 x UPTs/BCS | 24 x BCS |

*Weight is depending on the equipment



The M450e is a hydraulic mulcher for universal use with excavators of 12-20 tons and construction equipment.

Benefits for you:

- + Exceptionally simple handling
- + Maximum safety
- + Top shredding quality

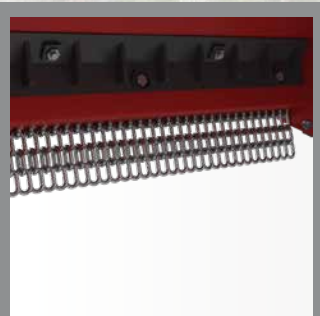

Stall protection
Counter blades prevent large objects infiltrating and stalling the rotor.



Closed housing
The closed housing improves safety by preventing wood and stones from flying out.

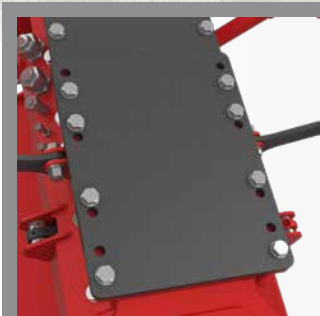

Flexible mounting
A universal plate enables the mulcher to be mounted on a wide variety of carrier vehicles.

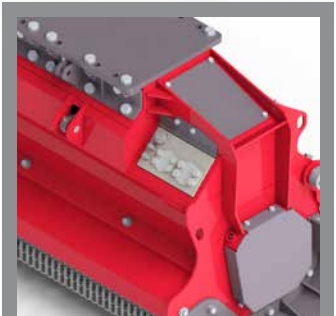

Variable displacement motor
The 80 cc motor with high pressure variable displacement allows individual adjustment with maximum torque.

| TECHNICAL SPECIFICATION | M450E-1100 |
|-------------------------|---------------------------------|
| Working width in [mm] | 43 [1100] |
| Overall width in [mm] | 54 [1382] |
| Volume flow gpm [L/min] | 21-53 [80-200] |
| Weight lbs [kg]* | 1521 [690] |
| Tools | 30 x HDT / 24 x UPTs / 24 x BCS |

*Weight is depending on the equipment.



M550e



The M550e is a hydraulic mulcher for universal use with excavators of 18-30 tons and for construction equipment.

Benefits for you:

- + High stability and lifetime
- + Reduced power requirement
- + Flexible configurable

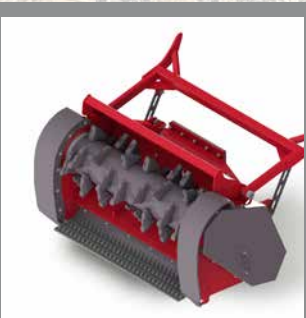

Coating of the housing

The housing itself with wear resistant liners at critical areas.



No hydraulic hoses

No hydraulic hoses at the outside of the housing, which can rip off or get damaged at heavy use.



Flexible mounting

A universal plate enables the mulcher to be mounted on a wide variety of carrier vehicles.



Two-stage counter blades

Made of highly wear-resistant steel - increases the crushing quality. An additional crushing of the material can be achieved through the counterblades in the flap. (Option)

| TECHNICAL SPECIFICATION | M550E-1300 |
|-------------------------|----------------------|
| Working width in [mm] | 51 [1300] |
| Overall width in [mm] | 66 [1680] |
| Volume flow gpm [l/min] | 21-69 [80-260] |
| Weight lbs [kg]* | 2932 [1330] |
| Tools | 32 x UPTs / 28 x BCS |

*Weight is depending on the equipment

TECHNICAL DATA

| | Working width in [mm] | Overall width in [mm] (x1) | Height in [mm] (y1) | Depth in [mm] (z) | Power class HP | Volume flow gpm [l/min] | Weight* lbs [kg] | Tools |
|--------------|-----------------------|----------------------------|---------------------|-------------------|----------------|-------------------------|------------------|---------------------------------|
| M450e | 35 [900] | 49 [1236] | 26 [656] | 27 [678] | max. 90 | 16-29 [60-110] | 992 [450] | 20 x UPTs/BCS |
| | 43 [1100] | 57 [1441] | 26 [656] | 27 [678] | max. 90 | 16-29 [60-110] | 1091 [495] | 24 x BCS |
| | 43 [1100] | 54 [1382] | 36 [910] | 32 [816] | 60-120 | 21-53 [80-200] | 1521 [690] | 30 x HDT / 24 x UPTs / 24 x BCS |
| M550e | 51 [1300] | 66 [1680] | 39 [979] | 46 [1161] | max. 250 | 21-69 [80-260] | 2932 [1330] | 32 x UPTs / 28 x BCS |

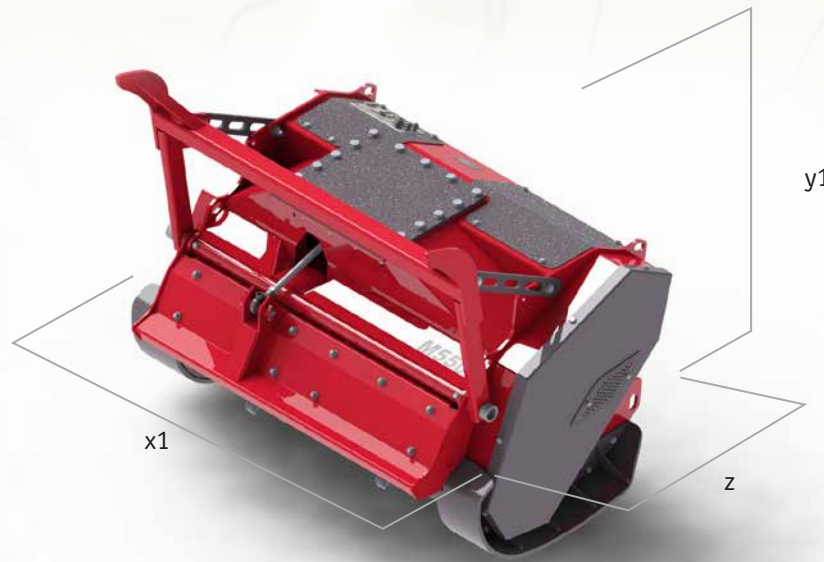

*Weight is depending on the equipment

TOOLS

BCS ROTOR SYSTEM

- + High cutting performance
- + Easy load handling while mulching



BCS02

BCS03

UPTS ROTOR SYSTEM

- + Best penetration capabilities
- + Reduced fuel consumption



UPTs02

UPTs04

UPTs07

UPTs08

HDT ROTOR SYSTEM

- + High flexibility
- + First-class mulch quality



HDT01

HDT02

HDT03

HDT04



Other sales and service sites can be found on www.prinoth.com

PRINOTH GmbH
Im Branden 15
88634 Herdwangen
GERMANY
Phone: +49 7557 9212 0
prinoth.germany@prinoth.com

PRINOTH AG
Brennerstraße 34
39049 Sterzing (BZ)
ITALY
Phone: +39 0472 72 26 22
prinoth@prinoth.com

PRINOTH Ltd.
1001, J.-A. Bombardier Street
Granby Qc J2J 1E9
CANADA
Phone: +1 450 776 3600
sales.na@prinoth.com