

The **Builtrite, 2/3 Tine Grapple** is designed to handle a wide variety of materials, from scrap steel to logs and rock. Built with T-1 Steel in its grapple arms and using AR 500 abrasion resistant tine tips, this grapple is designed to perform in extreme conditions, providing maximum durability and low maintenance, reducing your downtime. This grapple is excellent for loading and unloading stationary shears, balers and shredders. Its opposing jaw design is adept at aligning materials in the same plane, making it easier to load these machines. Key features include:

- High pressure, well protected cylinders.
- Heavy duty rotation using high torque motors (One on 2/3 SG 20T and two on 2/3 SG 30T) and heavy duty bearing.
- Grapple arms constructed of high strength, abrasion resistant steel. Tine tips made from AR 500 plate for maximum wear resistance.
- Heavy walled torque tubes run the entire width of the grapple frames, minimizing torsional (twisting) stresses.
- Oversized, hardened cylinder and pivot pins.
- Easily accessible, yet well protected grease zerks.

If you're looking for the toughest, most durable grapple on the market, look no further...make it a **Builtrite**.

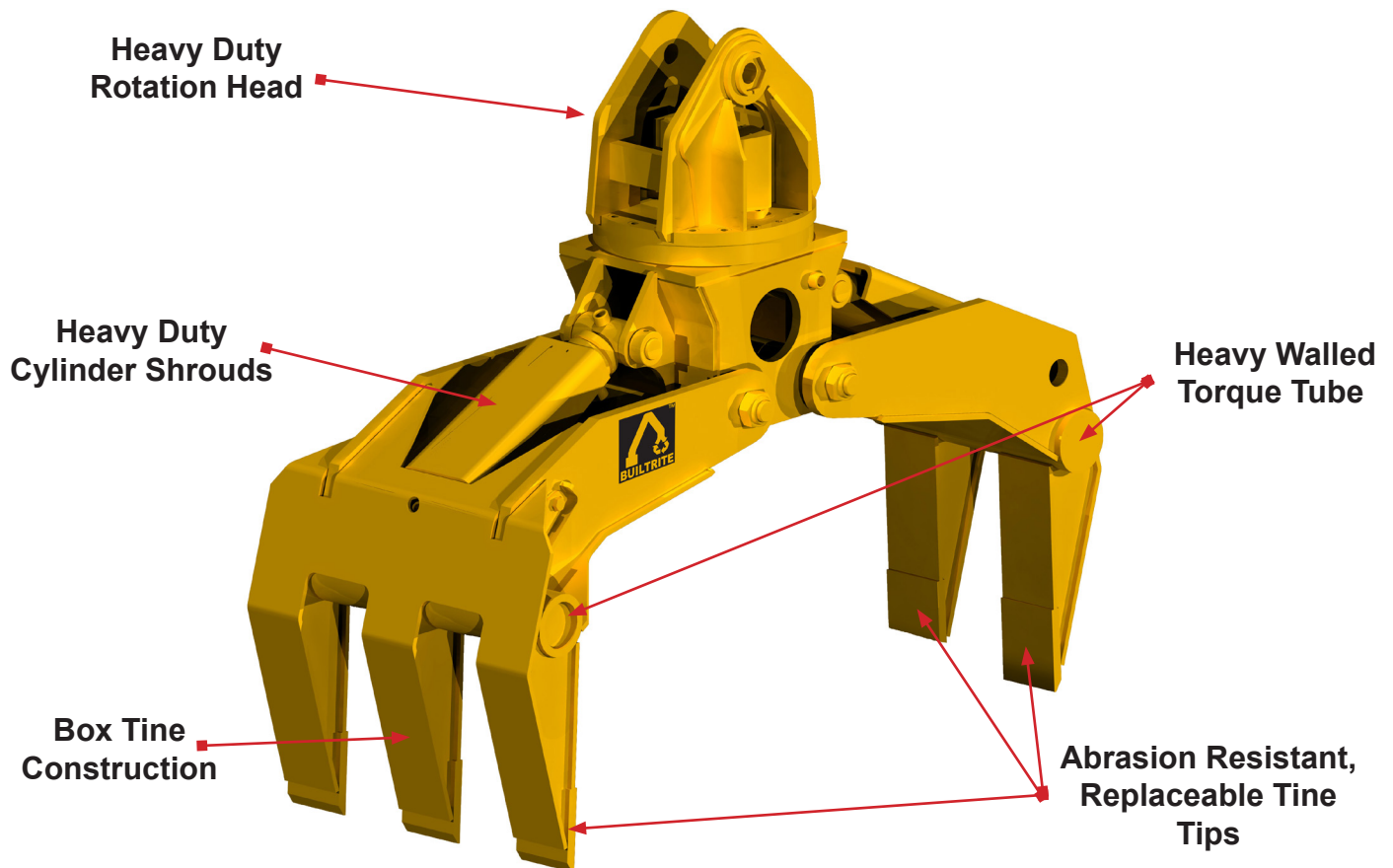

# 2/3 Tine Grapple Specifications

Model	Weight		Open Height (A)		Opening (B)		Width of Individual Tines (C)		Width of 3 Tine Half (D)		Height @ Full Close (E)		Opening @ Full Close (F)		Width of Grapple From Side View (G)	
	Lbs.	Kg.	in.	mm	in.	mm	in.	mm	in.	mm	in.	mm	in.	mm	in.	mm
2/3 SG 20T	2,400	1,091	23	584	66	1,676	6.375	162	35	889	65.5	1,664	10.9	276	32.6	828
2/3 SG 30T	3,000	1,364	24.8	630	93	2,362	6.375	162	35	889	74	1,880	14.8	376	35.6	904
2/3 SG 45T	5,300	2,409	36	914	105	2,667	7	178	39	991	90	2,286	16	406	42	1,067

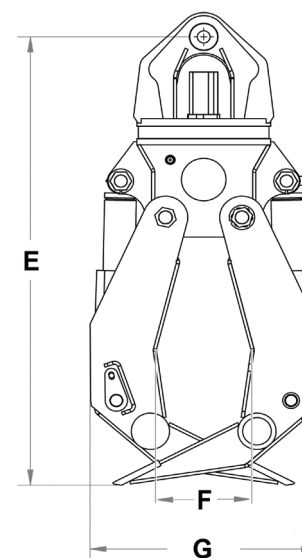
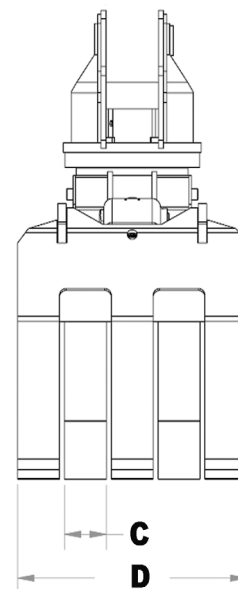
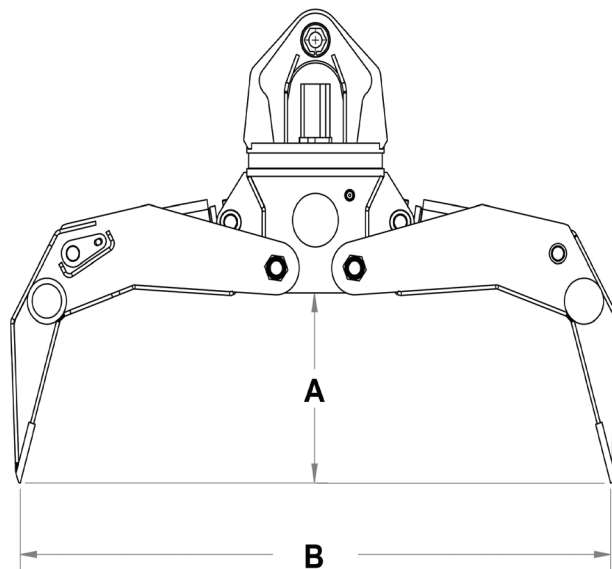

BUILTRITE MANUFACTURING RESERVES THE RIGHT TO CHANGE SPECIFICATIONS AND PRICES WITHOUT NOTICE IN ORDER TO FOLLOW ITS POLICY OF CONSTANTLY STRIVING TO MANUFACTURE A BETTER PRODUCT WITHOUT INCURRING ANY LIABILITY TO PROVIDE THESE NEW FEATURES ON ANY UNITS PREVIOUSLY MANUFACTURED.

## **Bultrite Manufacturing, Inc.**

530 Recycle Center Drive, Two Harbors, Minnesota, U.S.A. 55616

Web: [www.bultritehandlers.com](http://www.bultritehandlers.com) E-Mail: [info@bultritehandlers.com](mailto:info@bultritehandlers.com) Phone: 218-834-5555 Fax: 218-834-5556